

Modbus communication

Read Limits: Do not attempt to read more than 40 parameters (80 registers) in a single Modbus request to avoid exception errors.

RS485 communication interface, MODBUS RTU protocol:

- Baudrate: 9600 Baud (default, can be set)
- Parity: Even
- Databits: 8
- Stopbits: 1
- Default slave ID: 1 (SMD72D), 45 (SDM72CTM)
- Number of Drivers and Receivers: 32 Drivers, 32 Receivers (without repeater)
- Maximum Cable Length: 1200 m
- Maximum Data Rate: 10 Mbaud
- Maximum Common Mode Voltage: 12 V .. -7 V
- Minimum Driver Output Levels (Loaded): +/- 1.5 V
- Minimum Driver Output Levels (Unloaded): +/- 6 V
- Drive Load: Minimum 60 ohms
- Driver Output Short Circuit Current Limit: 150 mA to Gnd, 250 mA to 12 V, 250 mA to -7 V
- Minimum Receiver Input Resistance: 12 kΩ
- Receiver Sensitivity: +/- 200 mV

Convert word array to real array

The Input registers are in a word format and must be converted into real numbers in pairs. This conversion involves straightforward bit-level merging, which can be implemented in LabView, for example, as shown below:

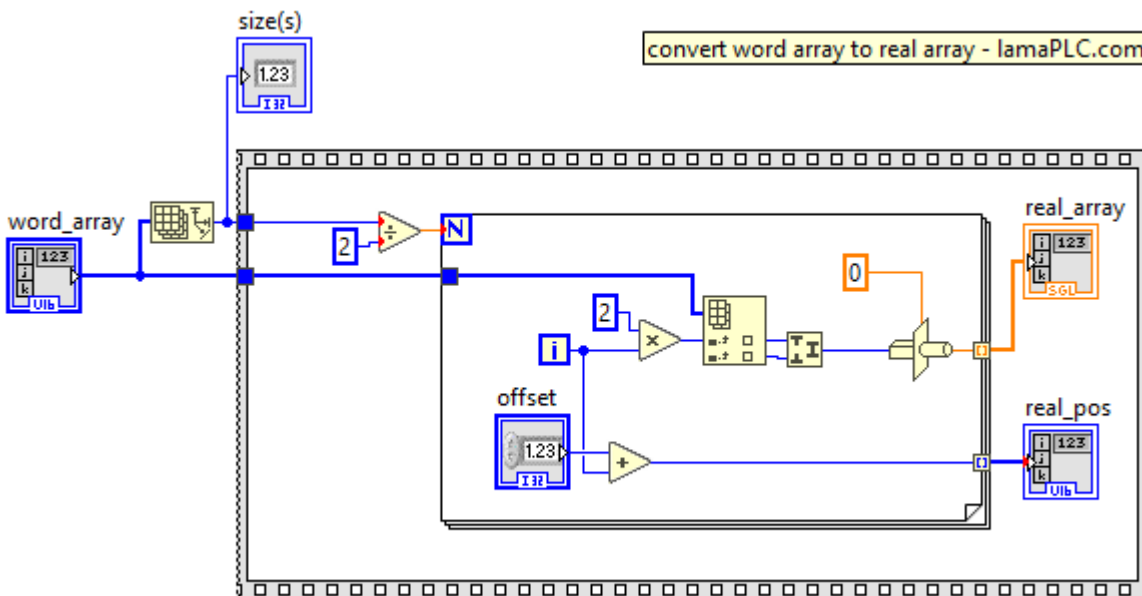

32-bit (2 words) input registers

The registers are read-only. All values are 4-byte IEEE 754 float type.

Register Nr	32 bit address	Description	Unit	Type
30001	1	Phase 1 line to neutral volts	Volts	SDM630, SDM230
30003	2	Phase 2 line to neutral volts	Volts	
30005	3	Phase 3 line to neutral volts	Volts	
30007	4	Phase 1 current	Amps	SDM630, SDM230
30009	5	Phase 2 current	Amps	SDM630
30011	6	Phase 3 current	Amps	SDM630
30013	7	Active Power Phase 1	Watts	SDM630, SDM230
30015	8	Active Power Phase 2	Watts	SDM630
30017	9	Active Power Phase 3	Watts	SDM630
30019	10	Apparent power Phase 1	VA	SDM630, SDM230
30021	11	Apparent power Phase 2	VA	SDM630
30023	12	Apparent power Phase 3	VA	SDM630
30025	13	Phase 1 volt amps reactive	VA _r	SDM630, SDM230
30027	14	Phase 2 volt amps reactive	VA _r	SDM630
30029	15	Phase 3 volt amps reactive	VA _r	SDM630
30031	16	Reactive power Phase 1 (pos: forward current, neg: reverse current)	-	SDM630, SDM230
30033	17	Reactive power Phase 2 (pos: forward current, neg: reverse current)	-	SDM630
30035	18	Reactive power Phase 3 (pos: forward current, neg: reverse current)	-	SDM630
30037	19	Phase 1 phase angle	Degrees	SDM630, SDM230
30039	20	Phase 2 phase angle	Degrees	SDM630
30041	21	Phase 3 phase angle	Degrees	SDM630
30043	22	Average line to neutral volts	Volts	SDM630
30047	24	Average line current	Amps	SDM630
30049	25	Sum of line currents	Amps	SDM630
30053	27	Total system power	Watts	SDM630
30057	29	Total system volt amps	VA	SDM630
30061	31	Total system power factor	VA _r	SDM630
30063	32	Total system power factor (pos: forward current, neg: reverse current)	-	SDM630
30067	34	Total system phase angle	Degrees	SDM630
30071	36	Frequency of supply voltages	Hz	SDM630, SDM230
30073	37	Total Import Energy	kWh	SDM630, SDM230
30075	38	Total Export Energy	kWh	SDM630, SDM230
30077	39	Total Import Reactive Energy	kVA _r h	SDM630, SDM230
30079	40	Total Export Reactive Energy	kVA _r h	SDM630, SDM230
30081	41	Total Power	kVAh	SDM630
30083	42	Current Hour	Ah	SDM630

Register Nr	32 bit address	Description	Unit	Type
30085	43	Total system power demand (power sum demand calculation is for import - export)	W	SDM630, SDM230
30087	44	Maximum total system power demand (power sum demand calculation is for import - export)	VA	SDM630, SDM230
30089	45	Current system positive power demand	W	SDM630, SDM230
30091	46	Maximum system positive power demand	W	SDM630, SDM230
30093	47	Current system reverse power demand	W	SDM630, SDM230
30095	48	Maximum system reverse power demand	W	SDM630, SDM230
30101	51	Total system VA demand	VA	SDM630
30103	52	Maximum total system VA demand	VA	SDM630
30105	53	Neutral current demand	Amps	SDM630
30107	54	Maximum neutral current demand	Amps	SDM630
30201	101	Line 1 to Line 2 volts	Volts	SDM630
30203	102	Line 2 to Line 3 volts	Volts	SDM630
30205	103	Line 3 to Line 1 volts	Volts	SDM630
30207	104	Average line to line volts	Volts	SDM630
30225	113	Neutral current	Amps	SDM630
30235	118	Phase 1 L/N volts THD	%	SDM630
30237	119	Phase 2 L/N volts THD	%	SDM630
30239	120	Phase 3 L/N volts THD	%	SDM630
30241	121	Phase 1 Current THD	%	SDM630
30243	122	Phase 2 Current THD	%	SDM630
30245	123	Phase 3 Current THD	%	SDM630
30249	125	Average line to neutral volts THD	%	SDM630
30251	126	Average line current THD	%	SDM630
30259	130	Phase 1 current demand	Amps	SDM630, SDM230
30261	131	Phase 2 current demand	Amps	SDM630
30263	132	Phase 3 current demand	Amps	SDM630
30265	133	Maximum phase 1 current demand	Amps	SDM630, SDM230
30267	134	Maximum phase 2 current demand	Amps	SDM630
30269	135	Maximum phase 3 current demand	Amps	SDM630
30335	168	Line 1 to line 2 volts THD	%	SDM630
30337	169	Line 2 to line 3 volts THD	%	SDM630
30339	170	Line 3 to line 1 volts THD	%	SDM630
30341	171	Average line to line volts THD	%	SDM630
30343	172	Total active energy (total kWh / kVarh equals Import + export)	kWh	SDM630, SDM230
30345	173	Total reactive energy (total kWh / kVarh equals Import + export)	kvarh	SDM630, SDM230
30347	174	L1 import active energy	kWh	SDM630
30349	175	L2 import active energy	kWh	SDM630
30351	176	L3 import active energy	kWh	SDM630
30353	177	L1 export active energy	kWh	SDM630

Register Nr	32 bit address	Description	Unit	Type
30355	178	L2 export active energy	kWh	SDM630
30357	179	L3 export active energy	kwh	SDM630
30359	180	L1 total active energy (total kWh / kVarh equals Import + export)	kwh	SDM630
30361	181	L2 total active energy (total kWh / kVarh equals Import + export)	kwh	SDM630
30363	182	L3 total active energy (total kWh / kVarh equals Import + export)	kwh	SDM630
30365	183	L1 import reactive energy	kvarh	SDM630
30367	184	L2 import reactive energy	kvarh	SDM630
30369	185	L3 import reactive energy	kvarh	SDM630
30371	186	L1 export reactive energy	kvarh	SDM630
30373	187	L2 export reactive energy	kvarh	SDM630
30375	188	L3 export reactive energy	kvarh	SDM630
30377	189	L1 total reactive energy (total kWh / kVarh equals Import + export)	kvarh	SDM630
30379	190	L2 total reactive energy (total kWh / kVarh equals Import + export)	kvarh	SDM630
30381	191	L3 total reactive energy (total kWh / kVarh equals Import + export)	kvarh	SDM630
30385	193	Current resettable total active energy	kWh	SDM630, SDM230
30387	194	Current resettable total reactive energy	kvarh	SDM630, SDM230

Source:

https://www.eastroneurope.com/images/uploads/products/protocol/SDM630_MODBUS_Protocol.pdf

SDM630/SDM230 Modbus Import registers in .csv file-format



If you'd like to support the development of the site with the price of a coffee — or a few — [please do so here](#).

Here's a handy tip: you can quickly save this page as a PDF by clicking "export to PDF" in the menu on the right side of the screen.

2026/02/14 23:38

32-bit (2 words) holding registers

The registers are read/write.

Address register	Parameter number	Parameter	Valid range	type	mode
40003	2	Demand period	Write demand period: 0, 5,8, 10, 15, 20, 30, or 60 minutes, default 60. Setting the period to 0 will cause the demand to show the current parameter value, and demand max to show the maximum parameter value since the last demand reset.	Length: 4 byte, Data Format: Float	rw
40011	6	System type	Write system type: 3p4w = 3, 3p3w = 2 & 1p2w= 1 Requires password, see parameter 13	Length : 4 byte, Data Format : Float	rw
40013	7	Pulse 1 width	Write pulse1 on period in milliseconds: 60, 100, or 200, default 100.	Length: 4 byte, Data Format: Float	r
40015	8	Password lock	Write any value to password lock-protected registers. Read password lock status: 0 = locked. 1 = unlocked. Reading will also reset the password timeout back to one minute.	Length: 4 byte, Data Format: Float	r
40019	10	Network Parity Stop	Write the network port parity/stop bits for MODBUS Protocol, where: 0 = One stop bit and no parity, default. 1 = One stop bit and even parity. 2 = One stop bit and odd parity.3 = Two stop bits and no parity.Requires a restart to become effective.	Length : 4 byte, Data Format : Float	rw
40021	11	Network Node	Write the network port node address: 1 to 247 for MODBUS Protocol, default 1. Requires a restart to become effective.	Length : 4 byte, Data Format : Float	rw
40023	12	Pulse1 Divisor1	Write pulse divisor index: n = 0 to 5 0: 0.0025 kWh(kVArh)/imp 1: 0.01 kWh(kVArh)/imp 2: 0.1 kWh(kVArh)/imp 3: 1 kWh(kVArh)/imp 4: 10 kWh(kVArh)/imp 5: 100 kWh(kVArh)/imp	Length : 4 byte, Data Format : Float	rw
40025	13	Password	Write password for access to protected registers. Default: 0000	Length: 4 byte, Data Format: Float	rw
40029	15	Network Baud Rate	Write the network port baud rate for MODBUS Protocol, where: 0: 2400 baud 1: 4800 baud 2: 9600 baud, default 3: 19200 baud 4: 38400 baud Requires a restart to become effective	Length: 4 byte, Data Format: Float	rw

Address register	Parameter number	Parameter	Valid range	type	mode
40087	44	Pulse 1 Energy Type	Write MODBUS Protocol input parameter for pulse output 1: 1: import active energy 2: total active energy 4: export active energy, default 5: import reactive energy 6: total reactive energy 8: export reactive energy	Length : 4 byte, Data Format : Float	rw
461457	30729	reset	00 00 □reset the Maximum demand	Length : 2 byte, Data Format : Hex	w

From:
<https://lamaplc.com/> - lamaPLC

Permanent link:
https://lamaplc.com/doku.php?id=meas:eastron_sdm_modbus

Last update: **2026/06/05 15:55**

